

# PRORIL

60Hz

GOVOX Series, these vortex pumps feature a less impeller wear and longer pump life by a vortex flow that allows fibrous materials and solid matters to be pumped out without obstruction.

Sewage Pump

## GOVOX 204

Vortex Pump



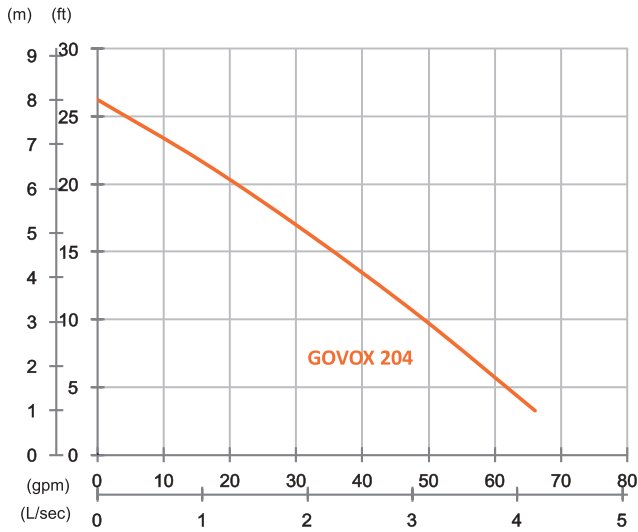

**GOVOX 204**

<b>OUTPUT</b>	0.5 HP (0.4 kW)
<b>OUTLET</b>	2" (50 mm)
<b>SOLID PASSAGE</b>	1.3" (32 mm)
<b>Weight</b>	31 lbs/14 kg
<b>HEAD</b>	Rated: 16 ft, 5 m Max: 26 ft, 8 m
<b>FLOW</b>	Rated: 32 gpm, 2 L/s Max: 66 gpm, 4.2 L/s

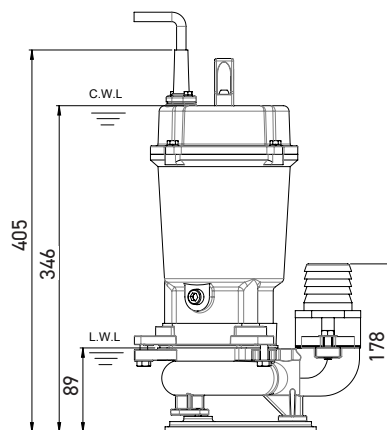
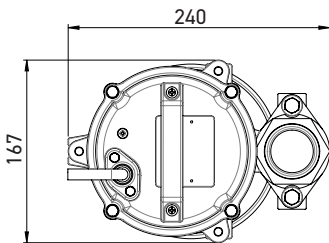

unit : mm  
C.W.L : Continuous running water level  
L.W.L : Lowest running water level

<b>Pump Type</b>	Electric Submersible Pumps	
<b>Motor</b>	<b>Phase</b>	1-Phase, 3-Phase
	<b>Type</b>	Induction Motor
	<b>Poles</b>	2 Pole (3450 rpm)
	<b>Insulation</b>	Class F
	<b>Protector</b>	Circle Thermal Protector
	<b>Starter</b>	1-Phase · Capacitor-Run, 3-Phase · D.O.L.
<b>Lubricant</b>	Food Grade (ISO VG32)	
<b>Specs.</b>	<b>Impeller Type</b>	Vortex
	<b>Shaft Seal</b>	Double Mechanical Seal
		Silicon Carbide VS Ceramic/Carbon
	<b>Bearings</b>	C3 Shielded ball bearings
	<b>Cable</b>	CSA-Certified PVC Jacketed Cables 33 ft (10 m) or longer upon request
<b>Materials</b>	<b>Pump Casing</b>	Gray Iron
	<b>Impeller</b>	Gray Iron
	<b>Motor Frame</b>	Gray Iron
	<b>Motor Shaft</b>	Stainless Steel
<b>Max. Liquid Temperature</b>	40°C (104°F)	
<b>Max. Submersion Depth</b>	20 m (66 ft)	
<b>pH Range</b>	pH 5 - pH 8	
<b>Guide Rail</b>	GRL-02	